



Optidrive Applications Support Library

Application Note	AN-IDL-001
Title	Using RCD's with Variable Frequency Drives
Related Products	All Products

Overview

In some cases, it is necessary for Residual Current Devices (RCD's) to be used in order to provide additional safety and protection of personnel during operation of a machine or plant equipment. Certain countries and industries have mandatory requirements in this respect.

When Variable Frequency Drives (VFD) are used with AC motors, some earth leakage current is inevitable. This may be low frequency current from the EMC filter inside the VFD, or may be high frequency current through the motor and motor cable.

In order to ensure that safety of personnel is maintained and that components used are compatible, this document provides guidance on the correct selection of RCD's.

RCD Purpose & Function

RCD's are generally used for two main reasons:

- Protection of personnel or animals against potentially dangerous electrical shock hazards
- Prevention of potentially dangerous leakage currents which may be a fire risk

For protection of personnel and animals, the trip currents which need to be monitored are low frequency and DC currents. The level of current which may flow before the device operates should be typically $\leq 30\text{mA}$. Due to the characteristics of human and animal bodies, high frequency currents are not conducted and therefore are much less important in this respect. In order to accurately reproduce this effect, a standard IEC test is used to measure "Touch Current". This is defined as the current that would flow through a typical body in the event of a fault.

Where RCD's are installed for fire protection, generally the current measurement required before the device trips are much higher, typically 300mA, however the range of frequencies measured is much larger.

RCD's are not intended to provide protection against faults such as short circuit to earth on power cables - some combined RCD and over current protection devices are available, however standard RCD devices do not provide over current protection. Protection against this type of fault should be by correct selection of fuses or circuit breakers in combination with the VFD's own internal short circuit protection and correct, safe machine design.

RCD Operation

Where RCD's are used, they must be installed in the supply line before the equipment they are intended to protect. The Earth connection must not be routed through the RCD. In principle, the RCD operates by measuring the total current in all phases (or phase and neutral for single phase). The sum of all currents should be zero. If the sum is non-zero, an additional current path exists indicating a leakage current to earth. If this leakage current exceeds the trip level the device must activate.

RCD Types

Several types of RCD are available. The table below gives an overview of the standard types.

RCD Type	Type of Residual Current Detection				
	Sinusoidal AC		Pulsating DC		Smooth DC
	Suddenly Applied	Slow Rising	Suddenly Applied	Slow Rising	
AC	✓	✓			
A	✓	✓	✓	✓	
B	✓	✓	✓	✓	✓

Note that the Type A device can only detect pulsating DC currents which touch or cross zero.

In addition to the above general categories, the following additional points should be considered when selecting an RCD to use with a VFD:

Time Delay

Where VFDs are fitted with an internal EMC filter, when the power is first applied to the VFD, the EMC filter capacitors are completely discharged. These capacitors must then charge at first power on. During this charging phase, the capacitors appear as a leakage path to earth for the RCD device, hence a short time delay is required before the device activates. This delay should be no more than 10ms, in order to ensure protection is maintained during a real fault condition.

Leakage Current Frequency Response

As described earlier, it is important to ensure that when RCD devices are used with VFDs, the correct type of RCD device is used to ensure the desired protection result. For example, where the RCD device is fitted to ensure protection of personnel during machine operation, the device must be suitable to detect the fault currents that could flow in this case, however it is also important to ensure that the device does not nuisance trip during operation. In this case, the RCD should have a high level of sensitivity to low frequency and DC currents, but should not trip due to high frequency leakage current which would not affect personnel safety.

If however, a device is fitted for fire protection purposes, it must be able to monitor all frequencies evenly at the desired trip current level.

The categories for RCD's described above do not provide information on time delay or frequency response characteristics. In this case, the RCD manufacturer can advise this information to allow correct selection.

Motor Type, Motor Cable Type and Length

The output of the VFD to the Motor is high frequency PWM. The motor and the motor cable itself provide a capacitive path to earth, meaning that the system has to be considered as a whole. As motor cable length increases, the capacitive effect and losses increase, and so earth leakage current also increases, especially at higher frequencies. Where RCD's must be used, the motor cable length must be kept as short as practical to avoid possible problems.

VFD Leakage Currents

The diagram below shows the topology of the VFD and motor circuit key components.

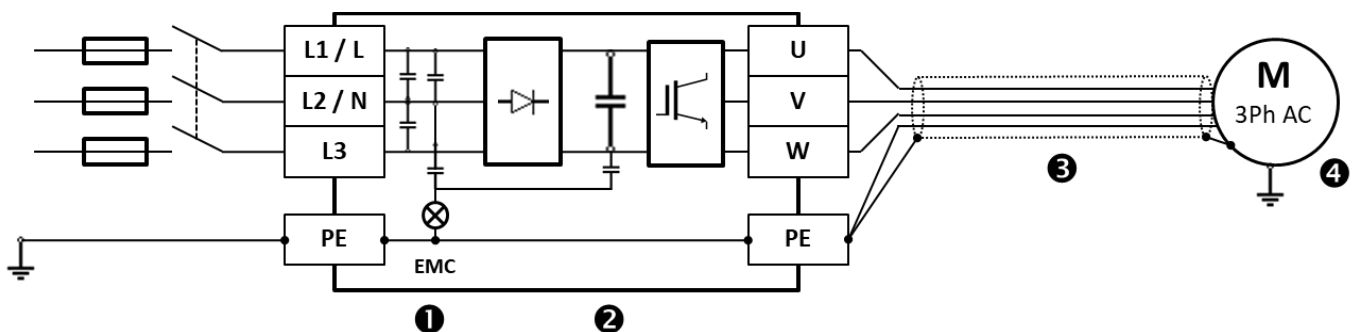

During normal operation, leakage currents may be present at the points indicated. These are:

- ❶ Leakage occurs through the input EMC filter, which may be disconnected. This is AC leakage current.
- ❷ Leakage additionally occurs through filter components connected to the drive DC link. This may be AC or DC leakage current. This may also be disconnected.
- ❸ The motor cable acts as a parallel plate capacitors. Leakage naturally occurs between phases and between phase and ground. This may be both AC and DC leakage current. The leakage current is affected by the motor cable type and length.
- ❹ The motor additionally has capacitive leakage to ground. This may also be both AC and DC leakage current. The current level depends on the motor construction.

Note – a supply phase imbalance (on 3 phase drives) can result in a significantly increased leakage current. This could happen when opening of closing breakers or isolators in the drive supply, which could give rise to nuisance tripping of the RCD.

Correct RCD Type Selection

When selecting a suitable RCD type to use with machinery which includes a VFD, it is important to consider the machine design as a whole, and also important to consider the type of fault that requires protection by the RCD.

The VFD itself takes a single or three phase AC input, converts to a smooth DC current internally and has a high frequency PWM output generated from this internal DC voltage. As such, the possible earth fault currents which can flow can be any of the following:

- Mains supply frequency AC current
- Smooth DC current
- Pulsed DC current
- High Frequency AC and DC currents

In order to ensure correct protection against the possible fault conditions which might occur, consider

- The primary reason for the RCD to be required, e.g. fire risk prevention or personnel protection?
- The risk associated with any fault which might occur
- The likelihood of occurrence
- How best to protect against such conditions.

The RCD should be considered the last line of protection if other methods have failed, or for protection against exceptional conditions.

When using an RCD for fire risk protection, a suitable trip level according to the local regulations should be selected. The RCD must be able to detect all fault types that may occur from misuse of the machine which are not protected by other means

When using an RCD for personnel protection, the RCD must be able to detect the fault current types which are possible. In general,

The first step is to determine the possible faults that the RCD should offer protection against. In the case where we are to consider protection of personnel, this should include:

- A fault on the incoming earth to the machine, e.g. the machine is accidentally operated without an earth connection.
- Possible damage or wear that could take place during the machine operation which might present a safety risk

Considering each of these cases in turn:

Machine Operated Without Earth Connected

In the case where a machine is inadvertently operated without the earth connected, any earth currents present which would normally flow harmlessly in the protective earth will circulate within the machine, which may then create a potential difference between the machine and the real earth. If an operator then touches any exposed metal on the machine, it is likely that a current will flow. From the diagram above, it is clear that this current can be low frequency AC or DC.

Appendix:

Revision History			
Issue	Comments	Author	Date
01	New Document Release	KB	13/02/18
02	Review of document	RG	03/09/2020